

**OPERATING INSTRUCTIONS**  
**FOR THE**  
**TYPE 202-B AM-FM**  
**SIGNAL GENERATOR**



**BOONTON RADIO CORPORATION**  
**BOONTON, NEW JERSEY**  
**U. S. A.**

**TABLE OF CONTENTS**

	<i>Page</i>
1. INTRODUCTION .....	3
a. General .....	3
b. Basic Operating Principles .....	3
2. OPERATING INSTRUCTIONS .....	4
a. Preliminary .....	4
b. Operational Checks .....	5
c. Operating Controls .....	5
d. Output Connections .....	6
3. SPECIFICATIONS .....	6
a. RF Range .....	6
b. Vernier Frequency Dial .....	6
c. RF Output Voltage .....	6
d. RF Output Impedances .....	6
e. Frequency Modulation .....	6
f. Amplitude Modulation .....	6
g. Distortion .....	6
h. Spurious RF Output .....	6
i. Fidelity Characteristics .....	6
j. Internal AF Oscillator .....	7
k. External Modulation Requirements .....	7
l. Tube Complement .....	7
m. Power Requirements .....	7
n. Dimensions and Weight .....	7
o. Accessories .....	7
4. THEORY OF OPERATION .....	7
a. Reactance Modulator Circuit .....	8
b. AF Oscillator .....	8
c. RF Oscillator .....	8
d. Amplifier Doubler Stage .....	8
e. Output Stage .....	8
f. Output Attenuator .....	9
5. MAINTENANCE INSTRUCTIONS .....	9
a. RF Unit .....	9
b. VR-150 Regulator Tube .....	9
c. Amplitude Modulation Adjustment .....	9
d. Frequency Modulation Adjustment .....	9
e. Trouble Shooting .....	9
Trouble Shooting Chart .....	9
Socket Voltage Chart .....	9
f. List of Replaceable Parts .....	9

**LIST OF ILLUSTRATIONS**

	<i>Figure</i>	<i>Page</i>
Basic Elements of 202-B AM-FM Signal Generator .....	1	3
Front Panel Controls of 202-B AM-FM Signal Generator .....	2	4
Receiver Connections .....	3	5
Basic Reactance Modulator Circuit .....	4	7
Output Attenuator Equivalent Circuit .....	5	9
Rear View of Panel Assembly, Power Supply, and Audio Oscillator.....	6	10
Sub-chassis View of Power Supply and Audio Oscillator .....	7	11
Schematic Wiring Diagram of 202-B AM-FM Signal Generator .....	8	15

## TYPE 202-B AM-FM SIGNAL GENERATOR

## 1. INTRODUCTION.

## a. GENERAL.

The Type 202-B Signal Generator has been specifically designed for use in the development and testing of frequency modulated receivers and television FM sound channel equipment within the frequency range of 54 to 216 megacycles. Provisions have also been made whereby it may be used in this frequency range as an amplitude modulated RF signal source or, in conjunction with an external audio oscillator, may be used to produce simultaneous FM and AM RF signals.

Physically this instrument consists of four major subassemblies: (1) panel assembly, (2) RF assembly, (3) audio oscillator, and (4) regulated power supply.

The RF unit is secured to the rear of the front panel while the audio oscillator and power supply are fastened to the bottom of the generator cabinet and are electrically connected to the front panel and RF assembly by means of cables and plug connectors.

The wiring and layout of the various components have been arranged for maximum simplicity resulting in a compact instrument of moderate size, thereby conserving laboratory space. All meters and calibrated controls are direct reading and are located on the front panel according to function. The frequency dial, as well as the modulation and output meters, has been

positioned at eye-level for maximum readability. Exclusive use of aluminum for cabinet, panel, and chassis fabrication has resulted in a relatively lightweight, easily portable instrument. For convenience in carrying a collapsible leather handle is attached to the top of the generator cabinet. This instrument is supplied complete with tubes, instruction book, and RF cable type number 501-A.

## b. BASIC OPERATING PRINCIPLES (Fig. 1).

Figure 1 shows in block form the basic elements employed in the 202-B Signal Generator. A type 6C4 triode is used as an RF oscillator and is tuned over the frequency range of 27-54 megacycles.

Coupled to the RF oscillator is a 6AK5 reactance tube, which, for frequency modulation, shifts the frequency of the oscillator in direct proportion to the instantaneous audio voltage applied to the reactance tube from the audio modulating oscillator.

The output from the RF oscillator is fed to a Class C frequency doubling stage which is tuned to the second harmonic of the oscillator frequency, thus covering a frequency range of 54 to 108 megacycles. Following this doubling stage is an output stage which in the low frequency range (54 to 108 mc) operates as a Class C amplifier and in the high frequency range

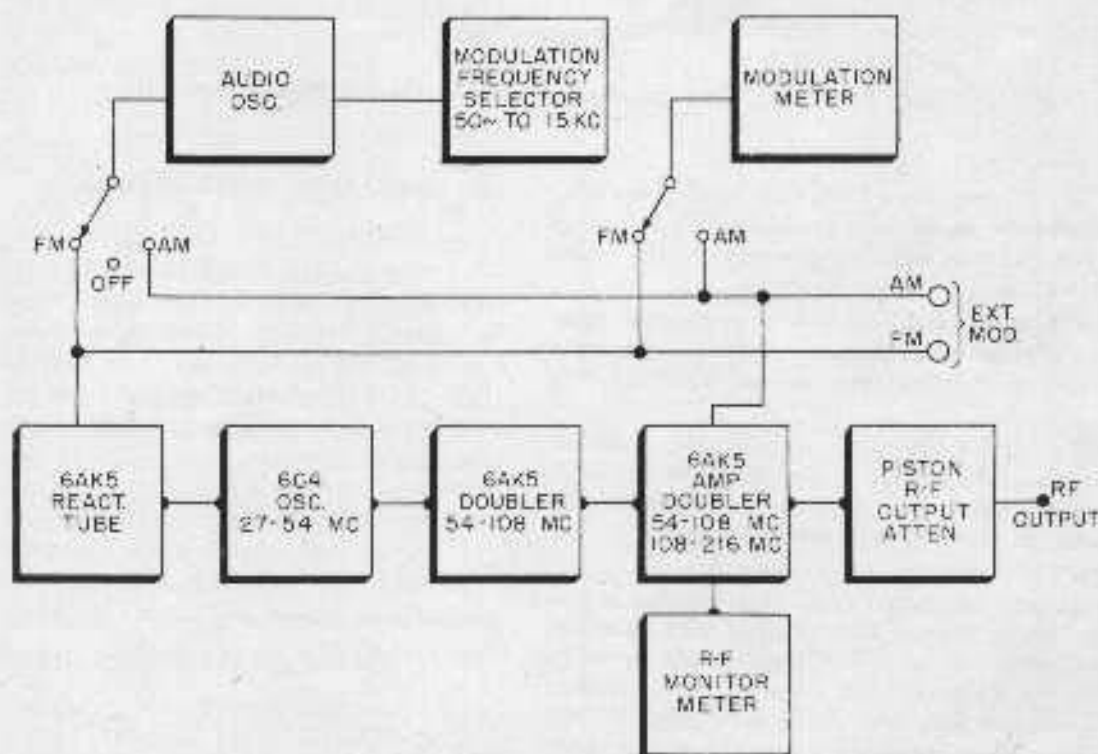

Fig. 1. Basic Elements of 202-B AM-FM Signal Generator

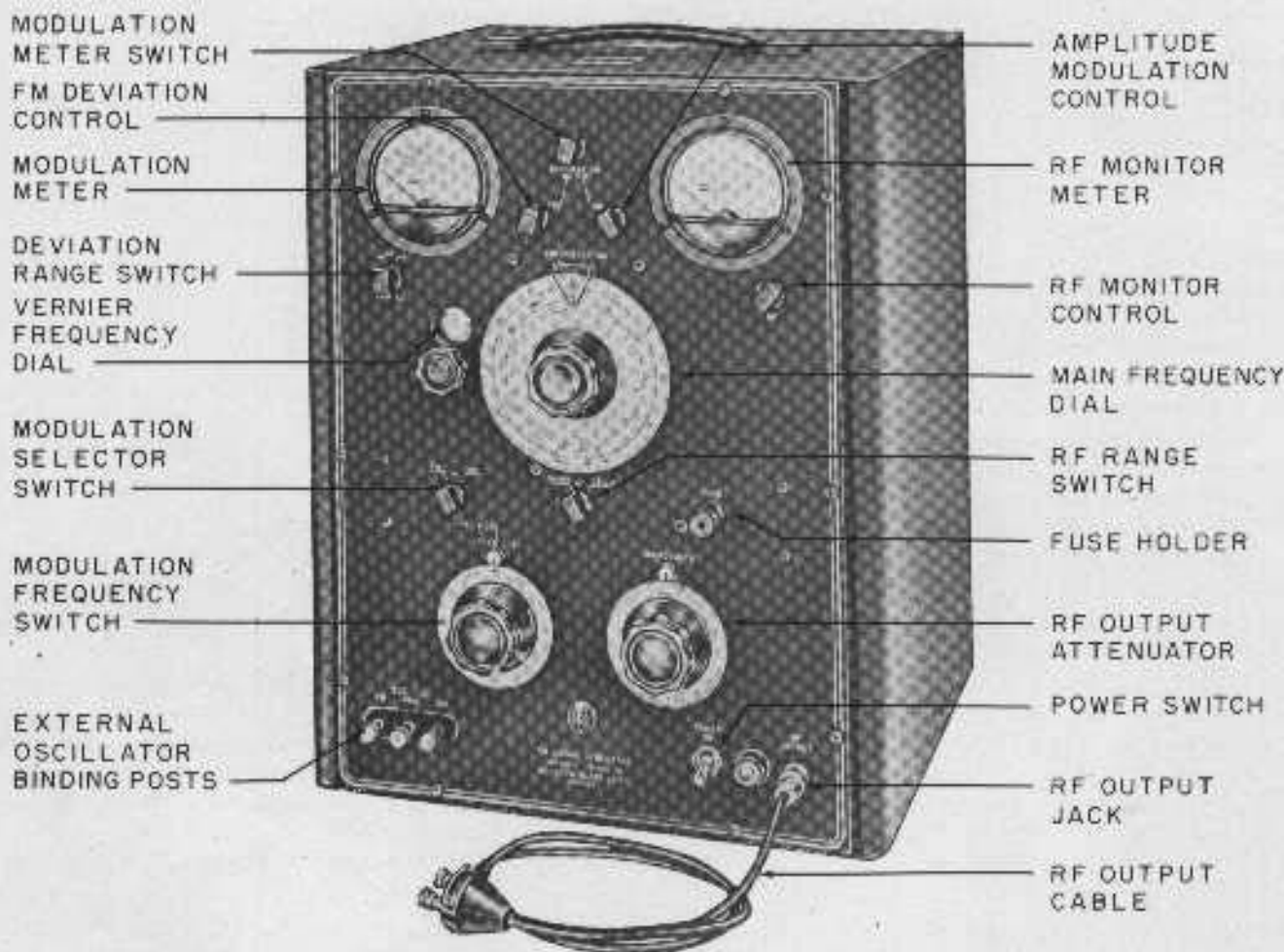

Fig. 2. Front Panel Controls of 202-B AM-FM Signal Generator

(108 to 216 mc) becomes a Class C frequency doubling stage. Amplitude modulation is obtained at this stage by applying an audio modulating voltage to the screen of the 6AK5 tube.

Coupled to the plate inductor of the output stage is a piston type mutual inductance attenuator having a 53-ohm resistor in series with the one turn coupling loop.

The dial of the attenuator is calibrated in microvolts in terms of the voltage present at the output cable terminal posts when the power output from the last stage is set to the proper level as indicated by the output monitor meter.

The 53-ohm RF output cable is terminated at one end by a 53-ohm resistor and terminal post assembly, and at the other end by a BNC type connector which attaches to the RF panel jack. The output impedance of the generator with this cable connected is 26.5 ohms. The voltage appearing across the output cable terminal posts is read directly on the output attenuator dial.

## 2. OPERATING INSTRUCTIONS.

### a. PRELIMINARY (Fig. 2).

The instrument should be carefully removed from the packing carton and the power cord plugged into a suitable 115 volt, 50-60 cycle outlet. Operate the POWER SWITCH to the "ON" position. Attach the RF OUTPUT CABLE to the front panel RF OUTPUT JACK by pushing in on the cable connector and rotating it clockwise.

### b. OPERATIONAL CHECKS.

As an indication that the instrument is in proper operating condition, the following checks should be made upon receipt and at suitable intervals thereafter:

#### 1. RF OSCILLATOR AND AMPLIFIER.

See that it is possible to adjust the RF MONITOR CONTROL to bring the needle of the RF MONITOR METER to the red reference line throughout the entire frequency range of 54-216 mc.



2. FM AND AM MODULATING SYSTEM.

Turn the MODULATION SELECTOR SWITCH to FM, the MODULATION SWITCH TO FM, and the DEVIATION RANGE SWITCH to 24 kc, 80 kc, or 240 kc. Operation of the FM DEVIATION CONTROL in a clockwise direction should cause the MODULATION METER to indicate increasing deviation.

Turn the MODULATION SELECTOR SWITCH to AM, the MODULATION METER SWITCH to AM, and rotate the AMPLITUDE MODULATION CONTROL clockwise. The MODULATION METER should indicate the percentage of amplitude modulation present, and full-scale setting should be possible.

If the above checks show the instrument to be faulty in any respect, consult the section on Trouble Shooting, Par 5c., as an aid in locating the cause of the trouble.

c. OPERATING CONTROLS (Fig. 2).

This section describes the functioning of the operating controls which are located on the front panel of the instrument starting with those at the lower left hand part of the panel and proceeding clockwise around the face of the instrument.

1. MODULATION FREQUENCY SWITCH.

This control selects any one of eight fixed audio frequencies between 50 cycles and 15 kilocycles for either frequency or amplitude modulation.

2. MODULATION SELECTOR SWITCH.

Either frequency or amplitude modulation may be obtained by setting this switch to the proper position. Modulation may also be turned off.

3. VERNIER FREQUENCY DIAL.

This dial is divided into 100 divisions and is coupled to the MAIN FREQUENCY DIAL through a 24:1 gear train, providing a total of 2400 logging divisions for each RF range.

4. DEVIATION RANGE SWITCH.

This rotary type switch selects three modulation meter deviation ranges, 0-24 kc, 0-80 kc, and 0-240 kc.

5. MODULATION METER.

Four modulation meter scales are provided, 0-24 kc deviation in 1-kc increments, 0-80 kc deviation in 5-kc increments, 0-240 kc deviation in 10-kc increments, and 0-50% amplitude modulation, with calibration marks at 30% and 50%.

6. FM DEVIATION CONTROL.

A continuously variable control for adjusting the frequency deviation on any of the three ranges 0-24 kc, 0-80 kc, or 0-240 kc.

7. MODULATION METER SWITCH.

By means of this control the MODULATION METER may be switched to either the FM or AM modulating system to indicate the degree of modulation present.

8. AMPLITUDE MODULATION CONTROL.

A continuously variable control for adjusting the amplitude modulation level.

9. RF MONITOR METER.

The RF MONITOR METER is used to standardize the power level of the last RF amplifier stage. In operation the meter pointer is set to the red calibration line on the meter scale.

10. RF MONITOR CONTROL.

This adjustment sets the RF MONITOR METER to the proper reference level such that the output attenuator calibration is direct reading in microvolts.

11. MAIN FREQUENCY DIAL.

The MAIN FREQUENCY DIAL has two frequency calibrations, 54-108 megacycles and 108-216 megacycles. An inner scale is divided into 24 equal divisions for use with the VERNIER FREQUENCY DIAL.

12. RF RANGE SWITCH.

This control selects either the low frequency range, 54-108 megacycles, the high frequency range, 108-216 megacycles, or turns the RF carrier off.

13. RF OUTPUT ATTENUATOR.

The RF OUTPUT ATTENUATOR DIAL is calibrated directly in microvolts output at the output cable terminals. It is standardized by setting the pointer of the RF MONITOR METER to the red calibration mark on the meter scale.

d. OUTPUT CONNECTIONS.

In order to properly match the output of the generator to the input impedance of a receiver under test, it may be desirable to add a resistor in one or both sides of the RF line from the signal generator as shown in figure 3.

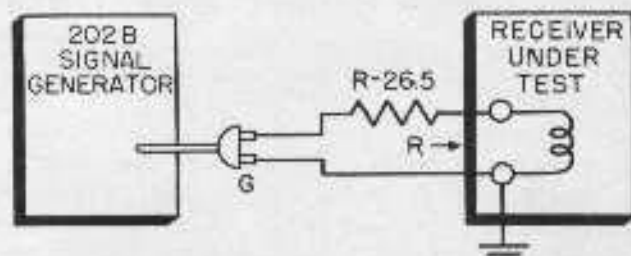

(a) UNBALANCED INPUT TO RECEIVER  
R=INPUT IMPEDANCE TO RECEIVER

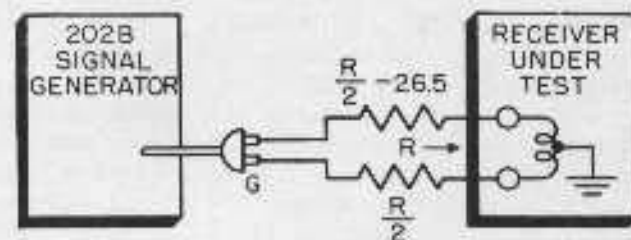

(b) BALANCED INPUT TO RECEIVER

Fig. 3. Receiver Connections

For the case of the unbalanced receiver input an impedance match may be obtained by connecting the proper resistance to the "high" signal generator terminal and connecting the ground of the signal generator to the receiver ground (figure 3a).

To use the signal generator with a receiver having a balanced input impedance, connections should be made according to figure 3b. As a check for the possibility of the ground between generator and receiver being low enough to shunt the padding resistor in the low side of the RF line, the power plug of the generator may be moved to a different outlet. Negligible change in readings should be observed.\* Resistors having nonreactive characteristics should be used to avoid errors due to phase change.

#### d. SIMULTANEOUS FM AND AM.

For certain tests simultaneous FM and AM is sometimes desired. The 202-B AM-FM Signal Generator, in combination with an external low distortion audio oscillator, may be used for this purpose provided that the audio oscillator is capable of developing approximately 5 volts across a 1500 ohm load, the FM requirement for 240 kc deviation.

In use the external audio oscillator is connected to the FM external binding posts, the MODULATION SELECTOR SWITCH set to AM, and the levels of each type of modulation independently set on the MODULATION METER by operation of the MODULATION METER SWITCH, FM DEVIATION CONTROL, and AMPLITUDE MODULATION CONTROL.

#### CAUTION:

*Use of an external audio oscillator for AM, with the INTERNAL MODULATION OSCILLATOR switched to FM, will result in interaction between modulation circuits when both oscillators are operating at or near the same audio frequency.*

### 3. SPECIFICATIONS.

#### a. RF RANGE.

Overall frequency coverage of 54 to 216 megacycles in two ranges: 54-108 megacycles and 108-216 megacycles, accurate to within  $\pm 0.5\%$  after a warm-up period of one hour. The MAIN FREQUENCY DIAL is also calibrated in 24 equal divisions for use with the VERNIER FREQUENCY DIAL.

#### b. VERNIER FREQUENCY DIAL.

The VERNIER FREQUENCY DIAL is divided into 100 equal scale divisions and is mechanically coupled to the MAIN FREQUENCY DIAL by a 24:1 gear train, providing a total of 2400 logging divisions over each frequency range. The approximate frequency change per vernier division is 26 kc on the low range and 52 kc on the high range.

\*Various methods of obtaining push pull voltage from an unbalanced generator output are discussed in the RCA Review, Vol. VI, April 1942, Number 4, in an article entitled "Receiver Input Connections for U-H-F Measurement" by John A. Rankin.

#### c. RF OUTPUT VOLTAGE.

The maximum open circuit output voltage from the BNC type RF OUTPUT JACK at the front panel is about 0.4 volt. With the standard output cable (type 501-A) attached, the maximum calibrated output voltage at the cable terminals is 0.2 volt. When the RF MONITOR METER is set to the red calibration line and the standard output cable attached, the RF OUTPUT ATTENUATOR is direct reading in microvolts and continuously adjustable from 0.1 microvolt to 0.2 volt. Accuracy is approximately  $\pm 10\%$ .

#### d. RF OUTPUT IMPEDANCES.

The RF output impedance of the signal generator as seen looking into the BNC type front panel connector is 53 ohms resistive. With the standard output cable attached, the RF output impedance as seen looking into the output cable terminals is 26.5 ohms resistive.

#### e. FREQUENCY MODULATION.

Three frequency deviation ranges 0-24 kc, 0-80 kc, and 0-240 kc are provided, each continuously adjustable. The 0-24 kc deviation scale is calibrated in increments of 1 kc, the 0-80 kc scale in increments of 5 kc, and the 0-240 kc scale in increments of 10 kc.

#### f. AMPLITUDE MODULATION.

Amplitude modulation is available over the range from 0-50% with meter calibration points provided at 30% and 50% modulation.

#### g. DISTORTION.

1. FM. The overall FM distortion at 75 kc is less than 2% and at 240 kc less than 10%.

2. AM. The distortion present at the RF output for 30% amplitude modulation is less than 3% and for 50% AM less than 6.5%.

#### b. SPURIOUS RF OUTPUT.

All spurious RF output voltages are at least 30db below the desired fundamental. Total RMS spurious FM from the 60 cycle power source is down more than 50 db, with 75 kc deviation as a reference level.

#### i. FIDELITY CHARACTERISTICS.

The deviation sensitivity of the FM modulation system as a function of frequency is constant from dc to better than 10 kc. At 15 kc the deviation as indicated on the modulation meter is 0.5 db higher than the true value. The amplitude modulation system is also flat to 10 kc and is down 1.0 db at 15 kc.

#### j. INTERNAL AF OSCILLATOR.

The internal audio oscillator may be switched to provide either frequency or amplitude modulation or it may be switched off. External binding posts permit the use of an external AF oscillator for either FM or AM. The internal oscillator and an external low distortion AF oscillator may be used simultaneously to produce a signal which is frequency modulated at two different audio frequencies. With the internal oscillator switched for AM, an external AF oscillator may be used simultaneously to frequency modulate the AM signal.

The internal AF oscillator provides eight fixed frequencies which may be selected by a rotary type switch - 50, 100, 400, cycles, and 1, 5, 7.5, 10, 15 kc, accurate to within 5%. Harmonic distortion, in general, is less than 0.5%.

The output voltage of the internal oscillator is available at the external binding posts for synchronizing or other purposes.

#### k. EXTERNAL MODULATION REQUIREMENTS.

##### 1. Frequency Modulation.

The frequency deviation sensitivity is 50 kc per volt on the 0-240 kc deviation range and 16.6 kc per volt on the 0-80 kc deviation range. For external FM the input impedance is 1500 ohms maximum.

##### 2. Amplitude Modulation.

Approximately 45 volts is required for 50% modulation on either the high or low RF range. For external AM the maximum input impedance is 7500 ohms shunted with 1000 mmf.

##### 3. Audio Voltage for External Use.

There is available at the FM external oscillator binding posts about 5 volts AC maximum and at the AM external oscillator binding posts, 50 volts maximum.

#### l. TUBE COMPLEMENT.

Audio Oscillator .....	6AU6, 6V6GT/G	(V1, V2)
Rectifier .....	5Y3GT/G	(V3)
Voltage Regulator ..	VR-150	(V4)
Reactance Modulator.	6AK5	(V5)
RF Oscillator .....	6C4	(V6)
Doubler Stage .....	6AK5	(V7)
Doubler and Output	6AK5	(V8)
Ballast Resistor .....	6H-6	(R18)

#### m. POWER REQUIREMENTS.

The 202-B FM Signal Generator is designed for use with 115 volts, 50-60 cycles. It will operate satisfactorily, however, over a voltage range from 105-125

volts without changing the RF frequency by more than 0.05%. A two ampere fuse is placed in one side of the AC line for protective purposes. Power consumption is 65 watts.

#### n. DIMENSIONS AND WEIGHT.

Outside cabinet dimensions: 17" H, 13½" W, 11½" D.

Weight: 35 pounds.

#### o. ACCESSORIES.

Available as an accessory is the 207-A Univerter which, in combination with the 202-B FM Signal Generator, provides additional frequency coverage from 0.1 mc to 55 mc at unity gain. The 207-A Univerter consists of a local 150 mc oscillator, mixer stage, and broad band amplifier. The frequency of the local oscillator is factory adjusted and may be checked by obtaining zero-beat with the 202-B output at 150 mc. The output frequency of the 207-A Univerter is determined by subtracting 150 mc from the 202-B Signal Generator MAIN FREQUENCY DIAL reading.

In use the input cable of the 207-A unit is attached to the RF OUTPUT JACK of the 202-B Signal Generator and the type 501-A RF Output Cable is transferred to the output jack of the 207-A Univerter. Since the Univerter has unity gain, its output level is indicated directly by the RF ATTENUATOR setting of the 202-B instrument. The output impedance of the 207-A Univerter is approximately 26.5 ohms with output cable attached.

#### 4. THEORY OF OPERATION.\*

##### a. REACTANCE MODULATOR CIRCUIT

(Fig. 4).

A 6AK5 tube (V5) operating as an inductive element across the tank circuit of the 6C4 (V6) oscillator circuit is employed for reactance modulation. In order to maintain constant frequency deviation sensitivity over

\*Theory of operation and design information are given in an article in the November, 1946 issue of Electronics Magazine entitled "Design of F-M Signal Generator" by Donald M. Hill and Murray G. Crosby.

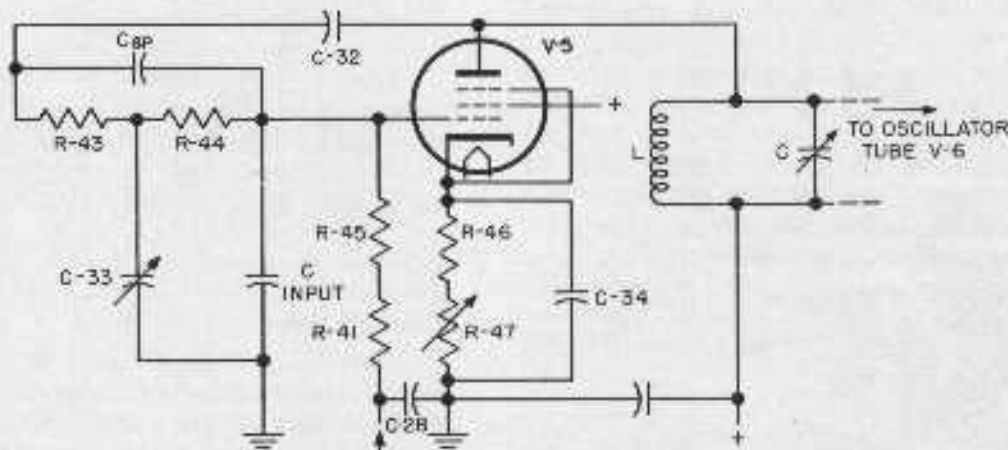

Fig. 4. Basic Reactance Modulator Circuit



the entire tuning range of the instrument the amount of inductance injected by V5 is made to vary directly as the carrier frequency. This is accomplished (fig. 4) by a bridged tee network consisting of R43, R44, C33, the grid plate capacitance of V5, and the grid cathode capacitance of V5. Although this circuit arrangement is capable of producing fairly constant deviation with fixed components, C33 is made variable and ganged with the oscillator tuning condenser to provide the precision of deviation calibration required in a signal generator.

Resistor R50 serves to bleed the proper amount of current through R46, R47 to permit operation of V5 over the most linear portion of its characteristics (fig. 8).

The cathode resistors R46 and R47 which provide bias for V5 are bypassed by C34 for radio frequencies only and degeneration takes place at audio frequencies. Resistor R47 is used to adjust the amount of degeneration present in order to provide the desired deviation sensitivity.

On the high RF range the modulation voltage for FM is reduced to one half in order to maintain the same frequency deviation (fig. 8). This is accomplished by means of resistors R23, R26, and switch S5 (fig. 8) which is mechanically coupled to the RF range changing switch. Switch S3 reduces the modulating voltage applied at the reactance tube to one third when operated from the 0-240 kc deviation position to the 0-80 kc deviation position, and to one tenth when operated from the 0-240 kc deviation position to the 0-24 kc deviation position.

For FM, an audio modulating voltage is applied directly to the grid of V3, the reactance tube, through an RF filter which prevents stray RF currents from leaking out of the shielded portion of the instrument.

#### b. AF OSCILLATOR (Fig. 8).

The AF oscillator employed is quite free from distortion having, in general, total harmonic content of less than 0.5%. The conventional Wein bridge type of R-C oscillator is used. The series and shunt R-C combinations required to provide the desired modulating frequencies are mounted directly on the rotary type selector switch and are connected by means of two leads to the AF chassis which mounts the oscillator tubes and components. Approximately 50 volts is available from the plate of the 6V6 tube (V2) for modulating purposes, the exact value being controlled by adjustment of R12 which regulates the amount of negative feedback voltage applied to the cathode of V1.

#### c. RF OSCILLATOR (Fig. 8).

A tuned plate RF oscillator covers the frequency range from 27.54 mc. Tuning over this range is accomplished by means of capacitor C39 which is ganged to the two other variable tuning capacitors C45 and C50. The plate of V6 is normally operated at about 150 volts DC.

#### d. AMPLIFIER DOUBLER STAGE (Fig. 8).

A frequency doubling stage (V7) follows the oscillator, and serves the two fold purpose of (1) permitting the oscillator to be operated at a lower frequency and (2) providing the desired isolation between oscillator and output stage to improve frequency stability. A further advantage is that it provides sufficient drive to saturate the output stage and thus remove any spurious amplitude modulation up to this point. This stage is self-biased and is arranged to track with the oscillator.

#### e. OUTPUT STAGE (Fig. 8).

The output stage employs a 6AK5 tube operating in Class C. For the low RF range, this stage functions as an amplifier, and over the high range becomes a frequency doubler. The output tank coil is provided with two contact points located so that when the ground contact is switched from the lower to the upper point, the inductance of the tank coil is changed to double the resonant frequency of the tank circuit. Switching is accomplished by two spring contact fingers, one or the other of which is pressed against a contact point by insulated members on the shaft of the RF RANGE SWITCH. This method avoids most of the mechanical and electrical difficulties usually associated with coil switching. The Q of the tank circuit has been selected to reduce spurious signals by more than 35 db and at the same time keep amplitude modulation to about 2% at 75 kc deviation.

Amplitude modulation is obtained by modulating the screen element of V8, sufficient isolation from the DC supply having been provided by the 50-henry choke, L2.

#### f. OUTPUT ATTENUATOR.

A piston type RF output attenuator having an internal impedance of 53 ohms is inductively coupled to the tank circuit inductor of the final stage. The pickup loop of the attenuator is continuously adjustable along the axis of the attenuator tube by means of a rack and pinion drive.

The RG58/U output cable and BNC panel fittings are of 53 ohm impedance and the output cable is terminated by a 53 ohm carbon resistor.

Figure 5 shows the basic design of the output attenuator system. The voltage induced in the attenuator coupling loop L20 in figure 5a is:

$$e' = I_0 M = \frac{E}{\omega L_{10}} \times \omega K \sqrt{L_{10} L_{20}} = EK \sqrt{\frac{L_{20}}{L_{10}}}$$

where  $\omega = 2\pi$  times the frequency, K is the coefficient of coupling between  $L_{10}$  and  $L_{20}$ , and M is the mutual inductance between  $L_{10}$  and  $L_{20}$ .

This equation shows that  $e'$  is a function of the tank voltage E and the coefficient of coupling K only. K is controlled by the attenuation law of the piston attenuator while E is monitored by the output monitor meter.



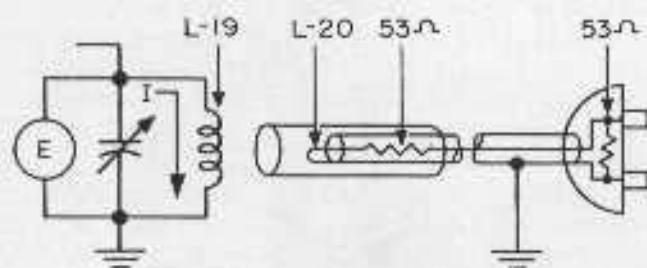

FIG. 5a

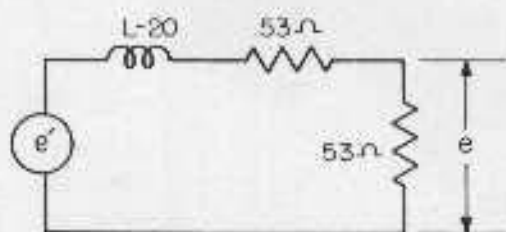

FIG. 5b

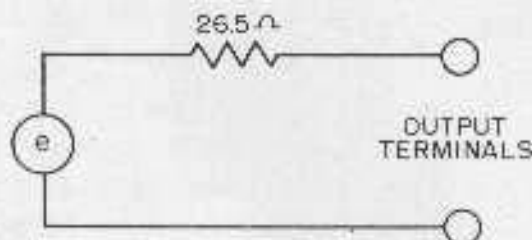

FIG. 5c

**Fig. 5. Output Attenuator Equivalent Circuit**

It can be seen from figure 5b that the voltage  $e$  across the terminating resistor is:

$$e = \frac{53e'}{106 - j(\omega L_{20})} = \frac{53e'}{\sqrt{(106)^2 + (\omega L_{20})^2}}$$

Since  $L_{20}$  is less than 0.01 microhenry,  $(\omega L_{20})^2$  can be neglected in comparison with  $(106)^2$  and:

$$e = \frac{e'}{2}$$

Neglecting  $L_{20}$  in figure 5b, an application of Thevenin's theorem yields the equivalent circuit shown in figure 5c. Thus the generator can be represented as a source voltage  $e$  in series with a resistance of 26.5 ohms. The attenuator dial is calibrated in terms of the open circuit output voltage  $e$  (Fig. 5c) and is direct reading in microvolts from 0.1 microvolt to 0.2 volt when the output monitor meter is set to the red reference line.

If the load impedance is not large compared with 26.5 ohms, the voltage applied to a load connected at the output terminals can be calculated by using the equivalent circuit of figure 5c.

## 5. MAINTENANCE INSTRUCTIONS.

### a. RF UNIT (Fig. 6).

This unit has been carefully adjusted and calibrated at the factory to meet the specifications listed in this instruction book. Specialized testing equipment and procedures are required which make field adjustments and replacements in the unit difficult and undesirable. For this reason, if any troubles are believed to have developed in the RF Unit, the Signal Generator should be returned to the factory for repair and readjustment, with the factory warranty being voided if our inspection shows damage or misalignment due to adjustments made by the customer.

The 60 cycle heater voltage between pin 5 of plug P-2 and ground (fig. 6) should measure 6.3 volts. If the RF unit is found to be inoperable and this voltage measures in excess of 7 volts, the trouble is probably due to an open heater circuit at one of the RF tubes. Continued operation of the instrument under this condition will damage the other RF tubes.

### b. VR-150 REGULATOR TUBE (Fig. 7).

When replacing this tube (V4) it is desirable to check its current drain by placing a milliammeter in series with the plate and adjusting R19 for a 7 milli-ampere plate current with the input voltage to the power transformer primary set at 105 volts. The adjustment will insure proper operation of the power supply over a line voltage range of 105-125 volts.

### c. AMPLITUDE MODULATION ADJUSTMENT.

If desired, the degree of amplitude modulation on the modulation meter can be checked by suitably mixing the output of the generator with another signal source such that a difference frequency of approximately 100-150 kc is produced. This difference frequency can be observed visually on a cathode ray oscilloscope and used for adjustment purposes. Adjustment of R35 (fig. 6) will change the modulation meter AM sensitivity to agree with that degree of modulation present.

### d. FREQUENCY MODULATION ADJUSTMENT.

The 6AK5 reactance modulator tube contained within the sealed RF unit has been carefully adjusted for a deviation sensitivity of 50 kc per volt on the low RF range, with the deviation range switch set at the 0-240 kc position. If for any reason it is desired to check the carrier deviation, this may be accomplished using the Crosby<sup>®</sup> or carrier zero method of measurement.

A selective communications superheterodyne receiver tuned to the RF output of the generator can be used as a null indicator to determine the exact point at which the carrier current disappears.

<sup>®</sup>Crosby, M.G., RCA Rev. 4, Page 349, 1940.

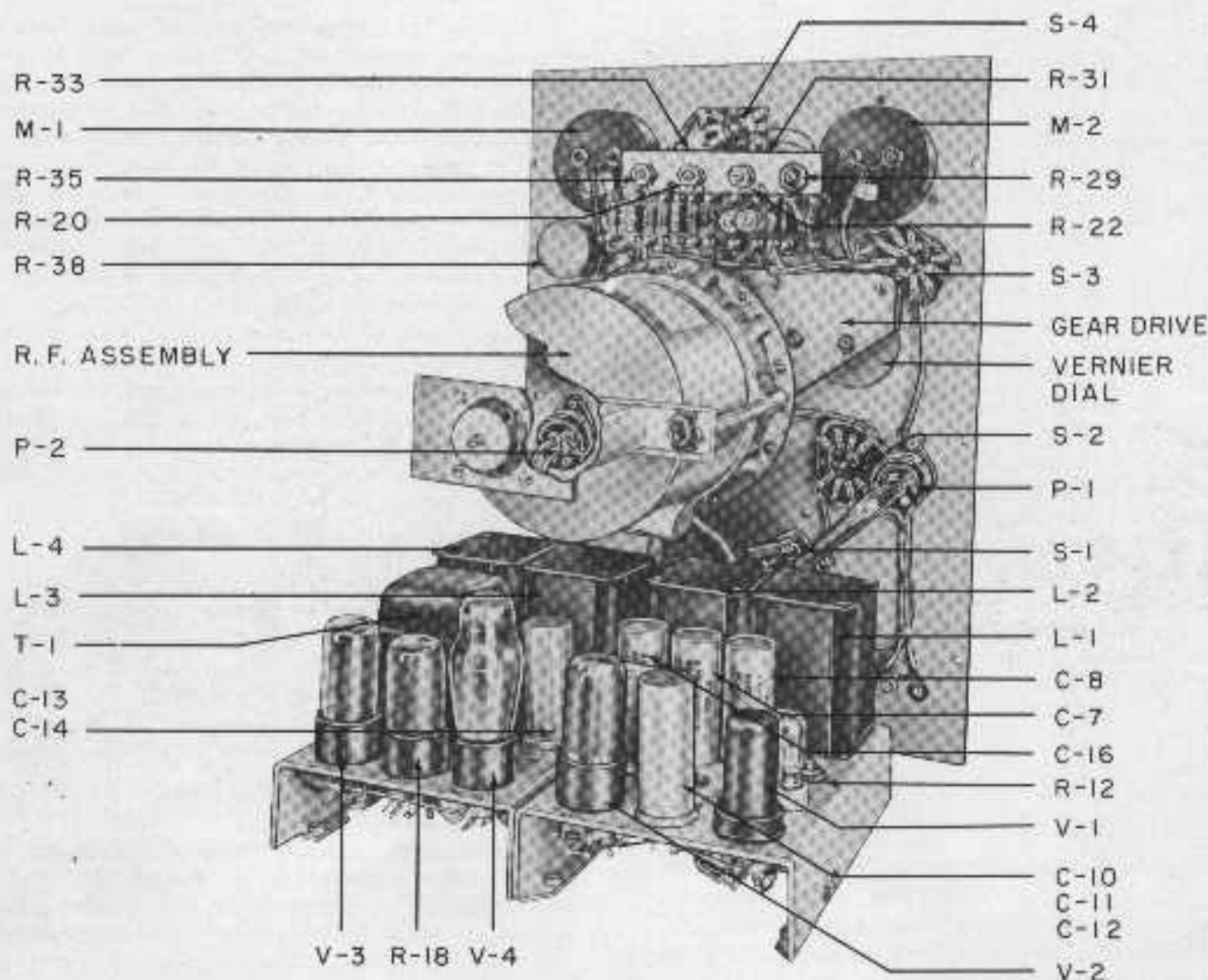

Fig. 5. Rear View of Panel Assembly, Power Supply, and Audio Oscillator

Since the modulation index  $B$  is defined as the ratio of the frequency deviation  $\Delta F$  to the modulating frequency  $f$ , or

$$B = \frac{\Delta F}{f}$$

the frequency deviation is given by:

$$\Delta F = B \times f$$

The carrier will reach its minimum value at the following modulation indices:

2.404; 5.5201; 8.653; 11.791; 14.930; 18.071; 21.2116, etc.

The FM deviation indicated on the modulation meter is controlled by the setting of R29 (fig. 6). A slight adjustment of this control may be made if desired, however the actual deviation sensitivity of the reactance modulator is adjusted by means of R47 (fig. 8) within the RF shield, and should not be disturbed.

*NOTE: No RF output will be obtained with the audio oscillator plug P, detached from the front panel assembly since the DC screen supply for the final amplifier doubler tube, V8, is wired from the power supply through the audio unit and thence to the RF panel.*

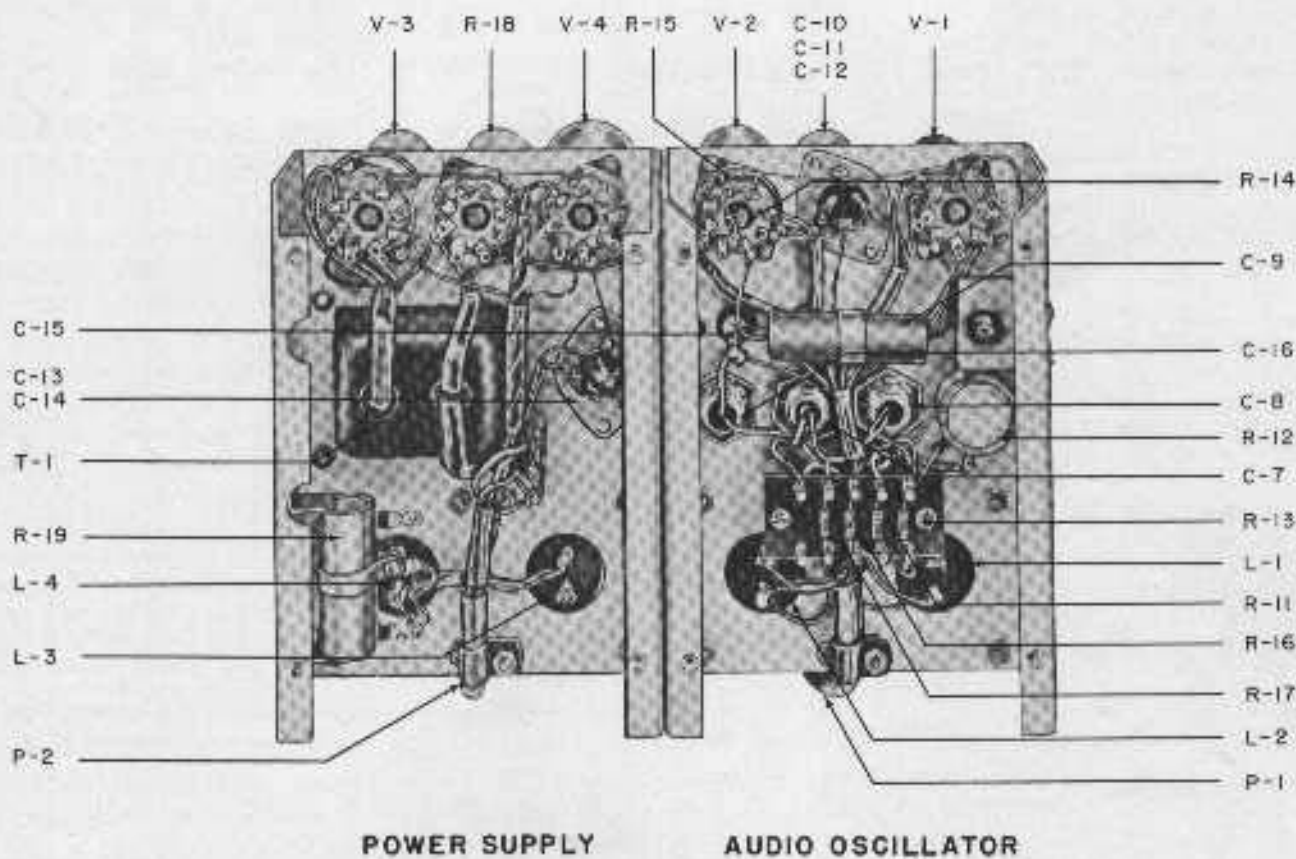

Fig. 7. Sub-chassis View of Power Supply and Audio Oscillator

**e. TROUBLE-SHOOTING.**

Many cases of non-operation or malfunctioning are the result of tube failure. A visual inspection will often show a tube inoperative, and its replacement will restore normal performance.

If all the tubes light, but performance is abnormal, the tubes should be checked in a tube tester, and returned, if good, to the sockets from which they were removed.

To facilitate the detection and localization of possible trouble, two charts are presented in the following pages. The first, a "Trouble Chart", lists by symptoms some known trouble conditions and their remedies. The second "Socket Voltage Chart", gives average operating potentials under the stated conditions.

**f. LIST OF REPLACEABLE PARTS.**

The following parts are replaceable. After replacement it is desirable to make the checks and adjustments described in par. 5, a, b, c, and d.



**TROUBLE CHART**

<i>Symptom</i>	<i>Cause</i>	<i>Correction</i>
With Equipment Connected to a suitable 115-Volt Source and Power Switch "ON", Panel lamp does not light.	Fuse Defective.	Replace fuse with 2A. Littlefuse No. 3AG-2.
	Panel Lamp Open.	Replace Panel Lamp.
	Primary winding or filament secondary winding of Power transformer open.	Check continuity of Transformer and replace if found defective.
Not all vacuum tube filaments light.	Defective Vacuum tube.	Test defective tube in tube tester. Replace R-18 with 6H-6 Ballast tube.
	Filament Ballast R-18 open.	
Fuse blows repeatedly as soon as power is applied, or blows sometime after power is applied.	V-3, C-12, C-13, C-14, or Power Transformer Defective.	Remove V-3. If fuse does not blow with V-3 removed, check C-12, C-13, C-14 for possible short. If normal, test V-3 in tube tester.
Filaments light but no Plate Voltages.	V-3 defective.	Replace V-3.
	L-3 or L-4 open.	Check continuity of L-3 and L-4.
	C-12, C-13, or C-14 shorted.	Check respective parts replacing any part found defective.
	Defective connection to terminal 3 of Plug P-2.	Check Terminal connections and wiring continuity of Plug P-2.
RF Unit Inoperative.	R-17 defective.	Check R-17 and replace if found defective.
	C-12 shorted.	Check C-12 and replace if found defective.
	Defective connection to terminal 2 of Plug P-2.	Check terminal connections and wiring continuity.

**SOCKET VOLTAGE CHART**

All voltages are DC unless otherwise indicated.  
 All DC measurements are made with 20,000 ohms per volt voltmeter.  
 All AC measurements are made with 1000 ohms per volt AC voltmeter.  
 Conditions for measurement:

- a. Measurements made with respect to ground.
- b. RF RANGE SWITCH set at 108-216 mc position.
- c. FREQUENCY MC DIAL set at 216 mc.
- d. ATTENUATOR DIAL set at 100K Microvolt.
- e. MODULATION SWITCH off.
- f. RF MONITOR METER set at red line.
- g. MODULATION METER SWITCH at FM.
- h. MODULATION FREQUENCY SWITCH at 400 cps.

Pin. No.	1	2	3	4	5	6	7	8
<b>Socket</b>								
V-1 (6AU6)	0	0	0	6.3AC	135	50	4	—
V-2 (6V6)	0	0	225	135	0	NC	6.3AC	4
V-3 (5Y3)	NC	330	NC	—9	NC	—9	NC	330
V-4 (VR-150)	NC	0	0	NC	150	NC	0	NC
R-18 (6H-6)	NC	14AC	NC	NC	NC	NC	6.8AC	NC

TYPE 202-B AM-FM SIGNAL GENERATOR

<i>Reference Symbol</i>	<i>Description</i>	<i>BRC Part No.</i>	<i>Mfg. &amp; Mfg's Designation</i>	
C-1,4	CAPACITOR, 10,000 $\mu\mu\text{f}$ , $\pm 2\%$ , 300 V, mica	82414		JAN CM40A103G
C-2,5	CAPACITOR, 1000 $\mu\mu\text{f}$ , $\pm 2\%$ , 500 V, mica	82302		JAN CM30C102G
C-3	CAPACITOR, 500 $\mu\mu\text{f}$ , $\pm 2\%$ , 500 V, mica	82234	Micamold	CM-20
C-6	CAPACITOR, 470 $\mu\mu\text{f}$ , $\pm 2\%$ , 500 V, mica	82239	Micamold	CM-20
C-7,54	CAPACITOR, 40 $\mu\text{f}$ , 150 V, electrolytic	83045	Aerovox	PRS-EP
C-8,16	CAPACITOR, 8 $\mu\text{f}$ , 450 V, electrolytic	83028	Aerovox	PRS-EP
C-9	CAPACITOR, 0.1 $\mu\text{f}$ , $+20\%$ , $-10\%$ , 400 V, electrolytic	83070	Aerovox	489
C-10,11,12, 13,14	CAPACITOR, 10-10-10 $\mu\text{f}$ , 400 V, electrolytic	83050	Malloy	FP-389
C-15	CAPACITOR, 1 $\mu\text{f}$ , $+20\%$ , $-10\%$ , 400 V, electrolytic	83066	Aerovox	418-CB
I-1	LAMP, Incandescent, 120 V, 3W	90907	GE	3S6/5
I-2	LAMP, Incandescent, 6.3 V, 0.15a	90904	GE	47
L-1,2	CHOKER, Filter, 50 h	85433	Freed	13134
L-3,4	CHOKER, Filter, 10 h	85535	Freed	13195
M-1	METER, 100 $\mu\text{a}$ , special scale	92026	Marion	HM3
M-2	METER, 100 $\mu\text{a}$ , special scale	92025	Marion	HM3
R-1,6	RESISTOR, 332K ohms, $\pm 1\%$ , $\frac{1}{2}$ W	80630	Wilkor	CP- $\frac{1}{2}$
R-2,7	RESISTOR, 166K ohms, $\pm 1\%$ , $\frac{1}{2}$ W	80567	Wilkor	CP- $\frac{1}{2}$
R-3,8	RESISTOR, 40.2K ohms, $\pm 1\%$ , $\frac{1}{2}$ W	80492	Wilkor	CP- $\frac{1}{2}$
R-4,9	RESISTOR, 31.2K ohms, $\pm 1\%$ , $\frac{1}{2}$ W	80491	Wilkor	CP- $\frac{1}{2}$
R-5,10	RESISTOR, 20.8K ohms, $\pm 1\%$ , $\frac{1}{2}$ W	80490	Wilkor	CP- $\frac{1}{2}$
R-11,21,34	RESISTOR, 100K ohms, $\pm 5\%$ , $\frac{1}{2}$ W	80517	AB	EB
R-12,29	POTENTIOMETER, 10K ohms, $\pm 10\%$ , 2W	81314	AB	J
R-13,16	RESISTOR, 53K ohms, $\pm 5\%$ , $\frac{1}{2}$ W	80461	AB	EB
R-14	RESISTOR, 220K ohms, $\pm 5\%$ , $\frac{1}{2}$ W	80555	AB	EB
R-15	RESISTOR, 150 ohms, $\pm 5\%$ , $\frac{1}{2}$ W	80098	AB	EB
R-17	RESISTOR, 100 ohms, $\pm 5\%$ , $\frac{1}{2}$ W	80062	AB	EB
R-18	RESISTOR, Thermal, glass.	91019	Amperite	6H-6
R-19	RESISTOR, Adjustable, 2.5K ohms, $\pm 5\%$ , 25W	80268	Wirt	AR-7
R-23,26	RESISTOR, 2K ohms, $\pm \frac{1}{2}\%$ , $\frac{1}{2}$ W	80283	IRC	RL
R-24	RESISTOR, 9.1K ohms, $\pm 5\%$ , $\frac{1}{2}$ W	80327	AB	EB
R-25,27	RESISTOR, 4K ohms, $\pm \frac{1}{2}\%$ , $\frac{1}{2}$ W	80266	IRC	RL
R-28	RESISTOR, 1950 ohms, $\pm \frac{1}{2}\%$ , $\frac{1}{2}$ W	80207	IRC	RL
R-30	RESISTOR, 6.8K ohms, $\pm 5\%$ , $\frac{1}{2}$ W	80387	AB	EB
R-31	POTENTIOMETER, 3K ohms, $\pm 5\%$ , 3W	81210	Centralab	V-133

BOONTON RADIO CORPORATION

Reference Symbol	Description	BRC Part No.	Mfgr. & Mfgr's Designation	
R-32	RESISTOR, 22K ohms, $\pm 5\%$ , $\frac{1}{2}$ W	80472	AB	EB
R-33	POTENTIOMETER, 25K ohms, $\pm 10\%$ , 3W	81411	Centralab	AF-115
R-35	POTENTIOMETER, 100K ohms, $\pm 10\%$ , 2W	81507	AB	J
R-36,37	RESISTOR, 33K ohms, $\pm 2\%$ , $\frac{1}{2}$ W	80486		
R-38	POTENTIOMETER, 15K ohms, $\pm 5\%$ , 3W	81331	Wirt	GCB
R-61,62	RESISTOR, 156K ohms, $\pm 1\%$ , $\frac{1}{2}$ W	80566	Wilkor	CP- $\frac{1}{2}$
R-63	RESISTOR, 8.2K ohms, $\pm 5\%$ , $\frac{1}{2}$ W	80326	AB	EB
R-93	RESISTOR, 470K ohms, $\pm 5\%$ , $\frac{1}{2}$ W	80640	AB	EB
S-1	SWITCH, Rotary, 4 pole, 8 position, 4 section	88058	Oak	32616-H4
S-2	SWITCH, Rotary, 2 pole, 3 position, 1 section	88056	Centralab	2TX8686
S-3	SWITCH, Rotary, 2 pole, 3 position, 1 section	88083	Centralab	2TX8686
S-4	SWITCH, Rotary, 2 pole, 2 position, 1 section	88060	Centralab	2TX8685
S-6	SWITCH, Toggle, DPDT	88059	AH&H	82305B
V-1	TUBE, 6AU6			
V-2	TUBE, 6V6			
V-3	TUBE, 5Y3			
V-4	TUBE, 6D3/VR-150			
X-1,2	CRYSTAL UNIT, Rectifying, germanium diode	91018	Sylvania	1N34
	RF UNIT, Complete	20205		
	TRANSFORMER, Power, filament and plate	85074	Freed	13643
	LIGHT, Indicator, miniature bayonet	89022	Dial	BV-844S
	LAMPHOLDER, candelabra base	89026	Bryant	328
	SOCKET, Tube, octal	89047	Ucinite	115001-1A
	CONNECTOR, Receptacle, one round female contact	89065	Industrial	UG-291/U
	SOCKET, Tube, 11 contact	89067	Amphenol	MIP-11
	SOCKET, Tube, 7 contact, miniature	89074	Eby	8083
	CONNECTOR, Receptacle, two female contacts	89076	AH&H	295
	CONNECTOR, Receptacle, recessed, two male contacts	89102	GE	2711
	FUSE, 2a	93251	Littlefuse	3AG-2
	HOLDER, Fuse, extractor post	93677	Bussman	HKP
	CONNECTOR, Plug, eight round male contacts	94148	Amphenol	PM-8-11
	CONNECTOR, Plug, eleven round male contacts	94149	Amphenol	PM-11-11
	CORD, Power, separable	300729		



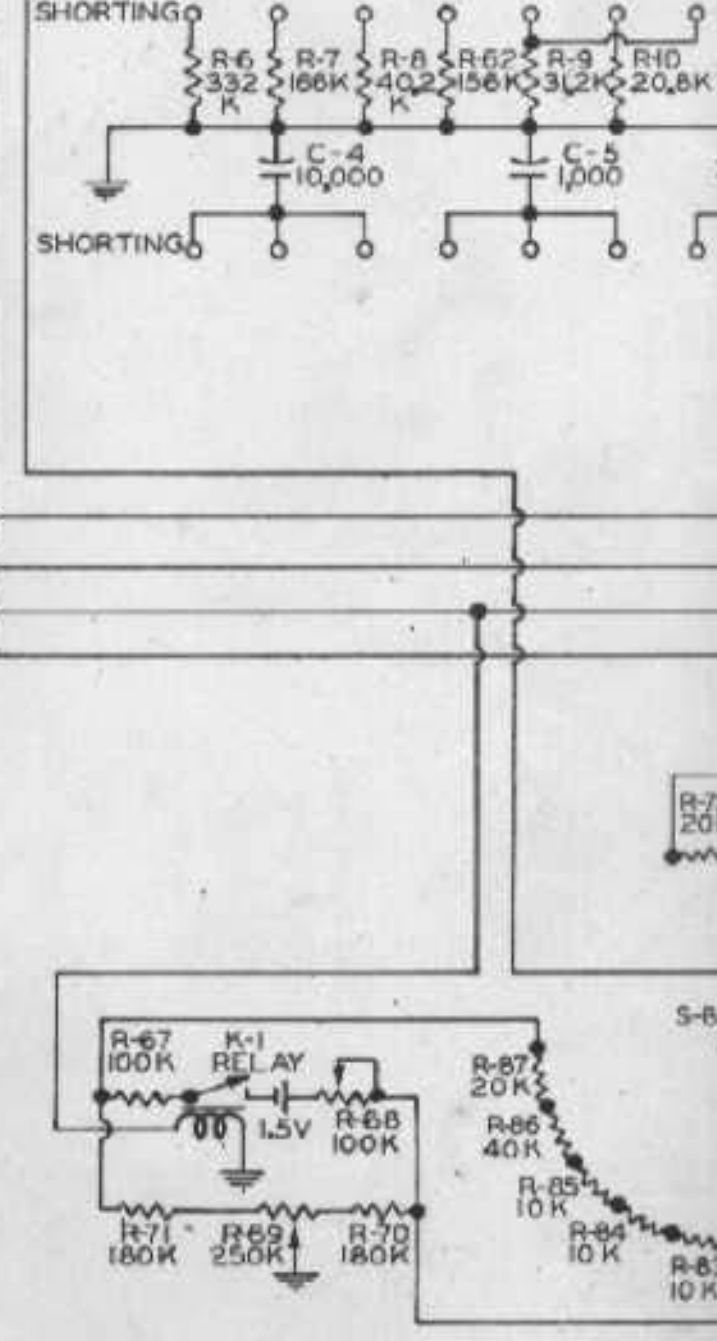
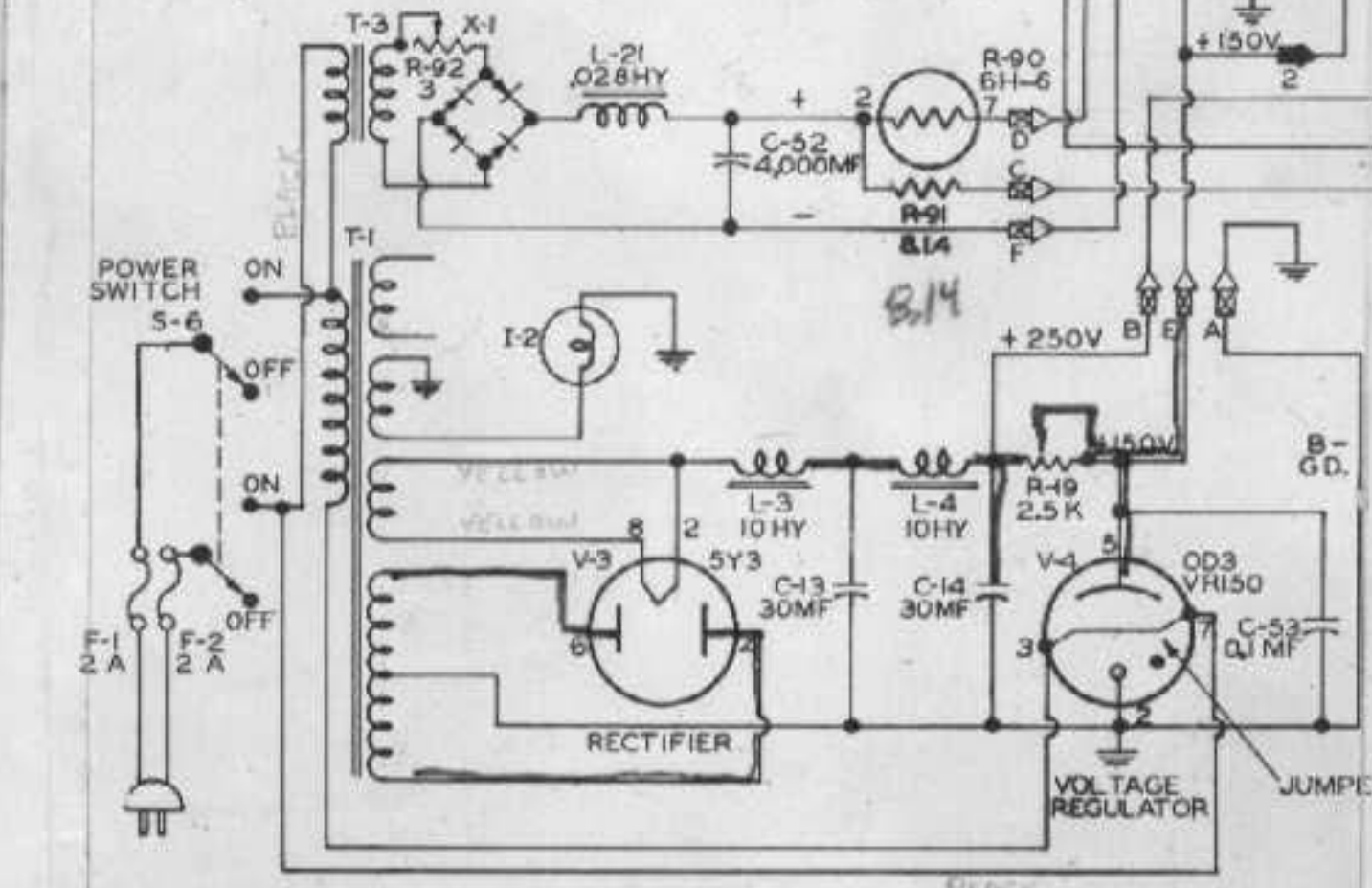
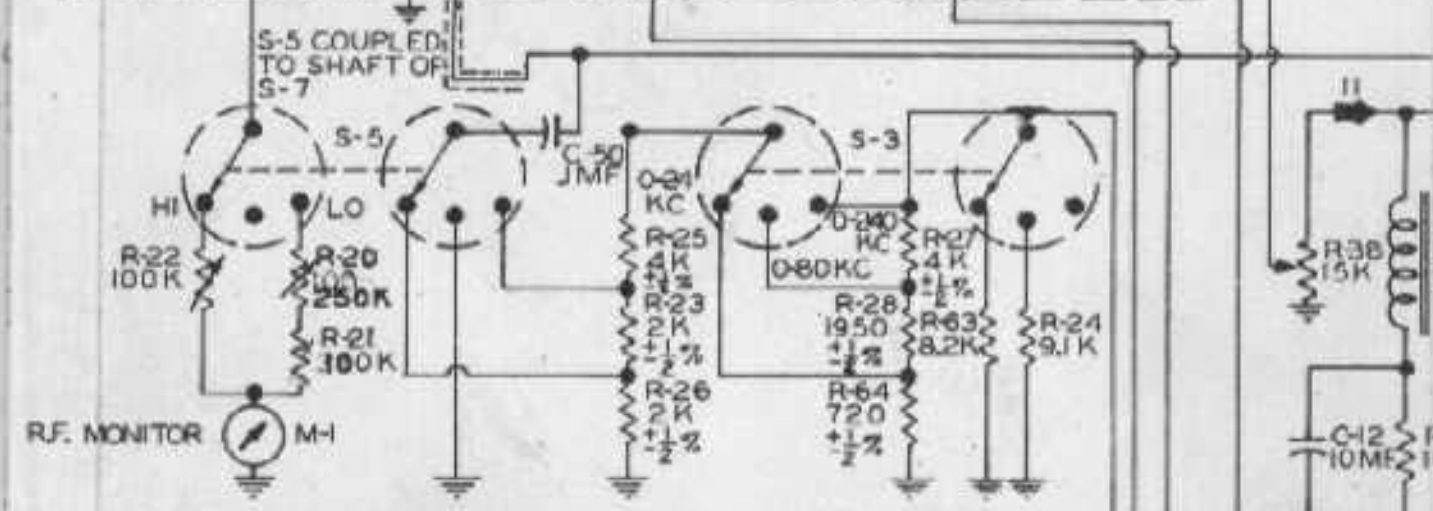
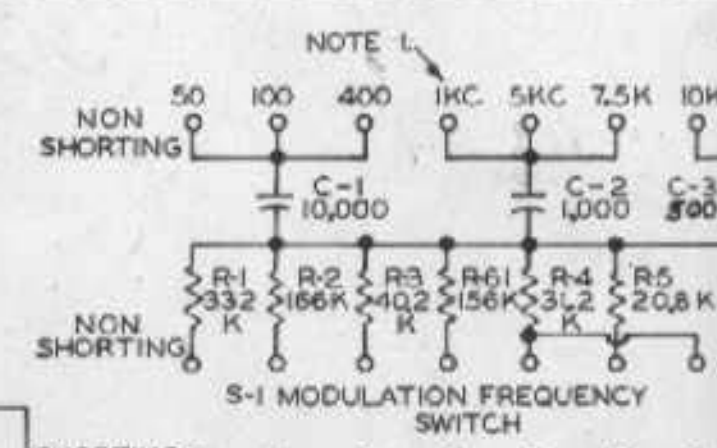
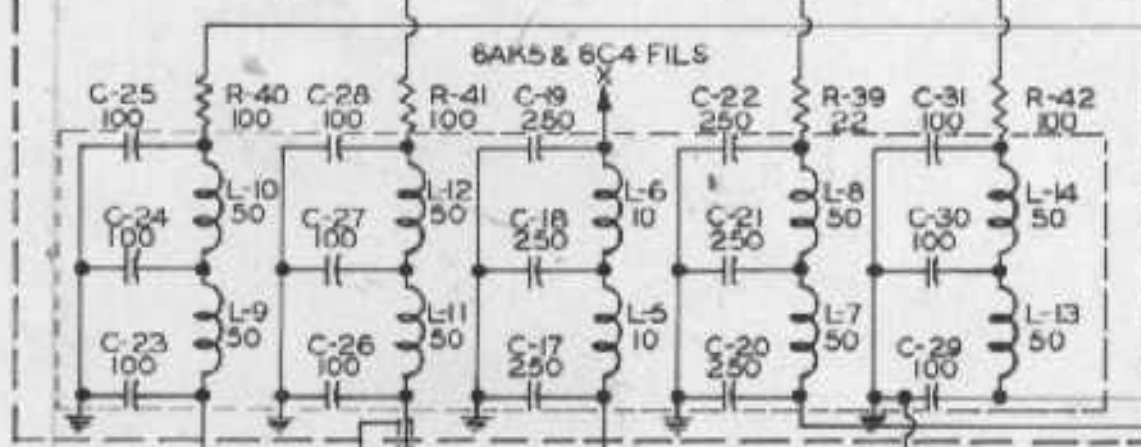
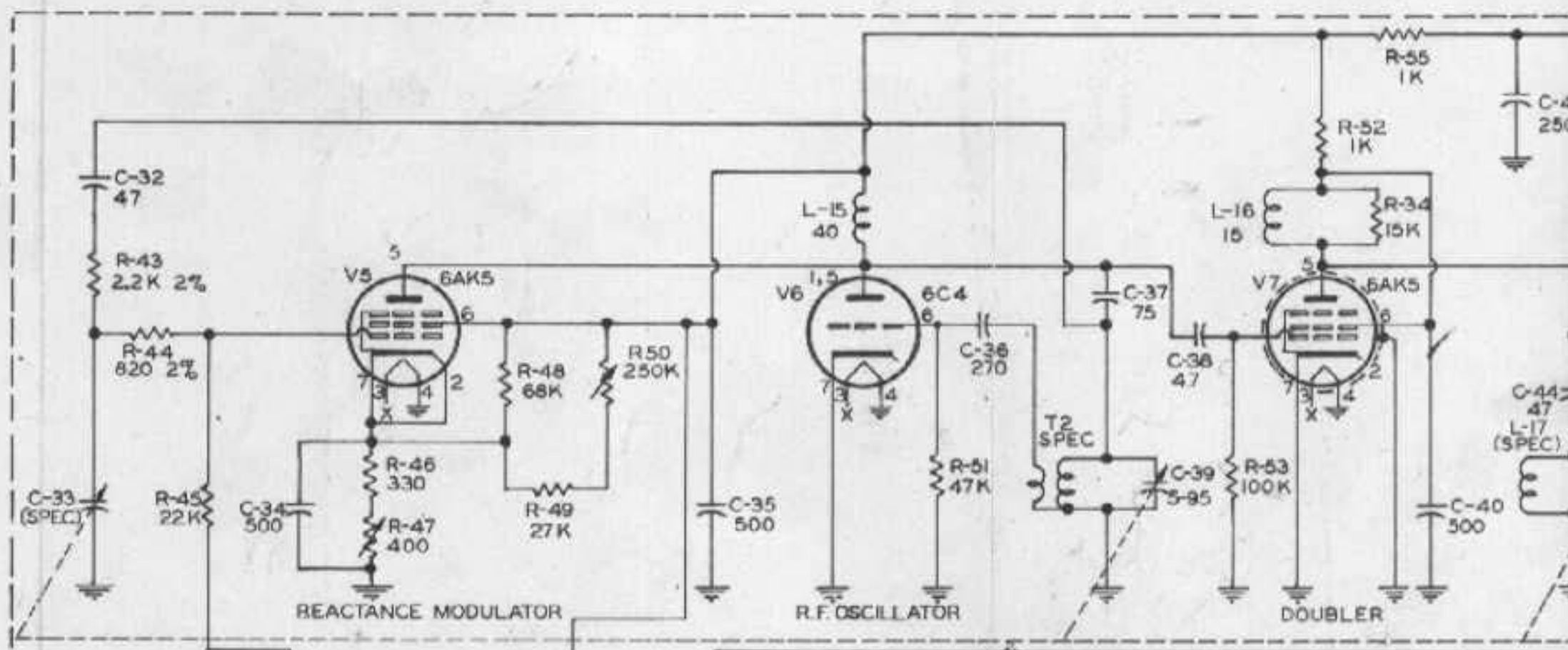

Red wire

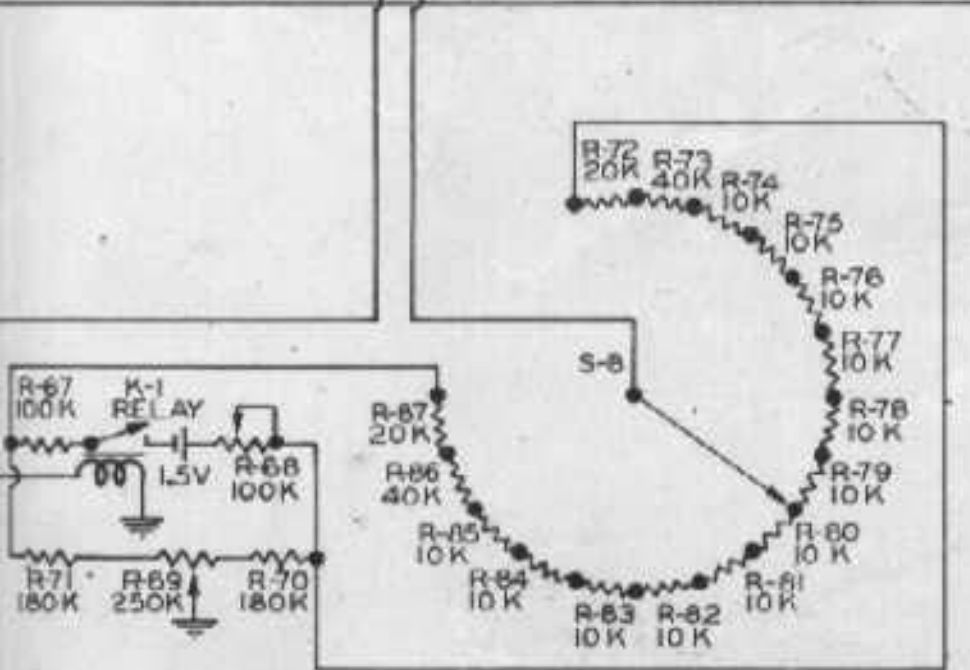
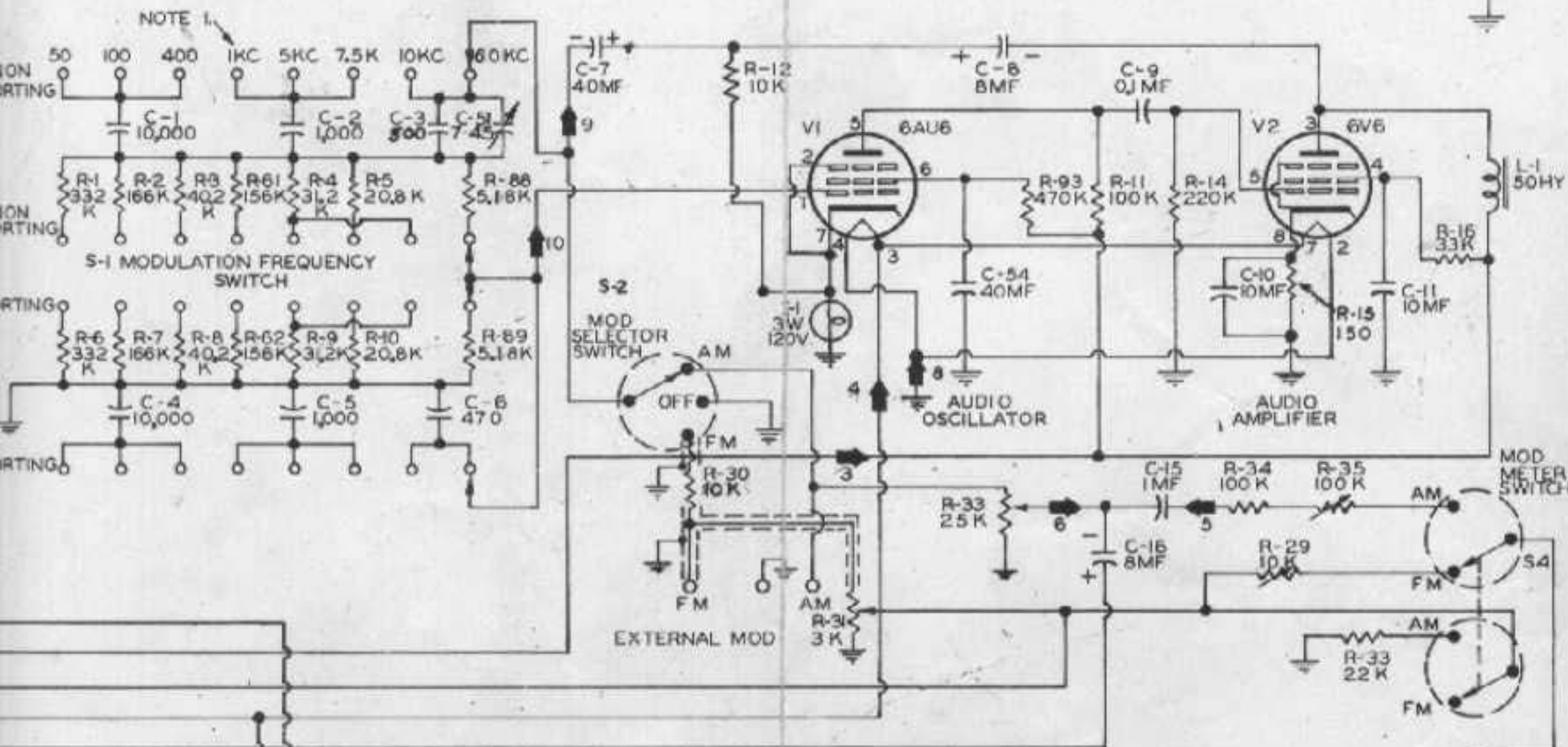
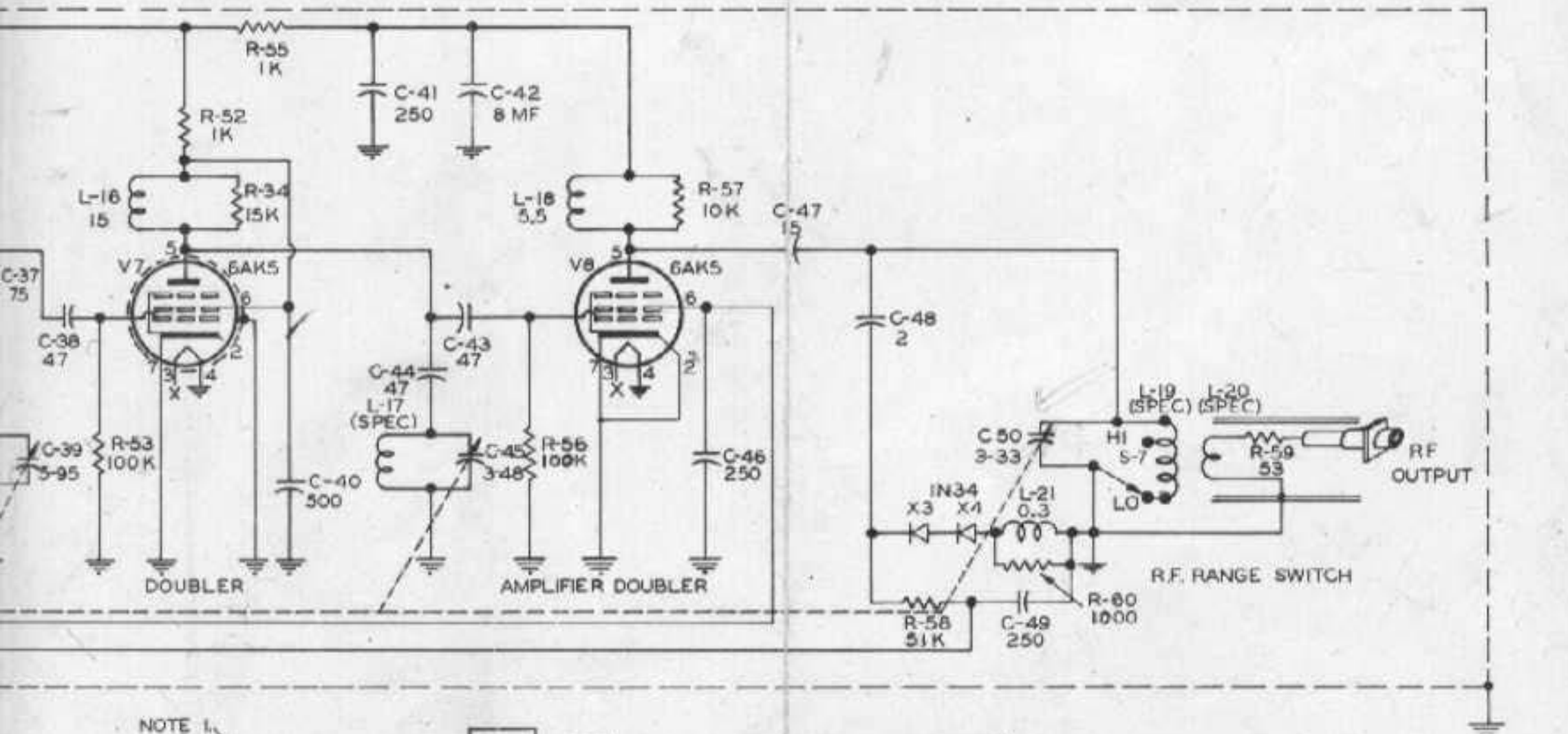

**PLUG CONNECTIONS**

■ OSCILLATOR CHASSIS PLUG P-1  
 ⊠ POWER SUPPLY PLUG P-2  
 POINT OF SYMBOL INDICATES DIRECTION OF WIRE COMING FROM PLUG PRONG INTO CABLE. NO. 1 PIN OF PLUG P-1 CONNECTS TO GROUND.  
 RESISTANCE IN OHMS, CAPACITANCE IN MICROMICROFARADS, INDUCTANCE IN MICROHENRIES, UNLESS OTHERWISE SPECIFIED (K=1,000, M=1,000,000)

**NOTE 1.**  
 FREQUENCIES IN CPS OF AUDIO OSCILLATOR FOR GIVEN POSITION OF S-1

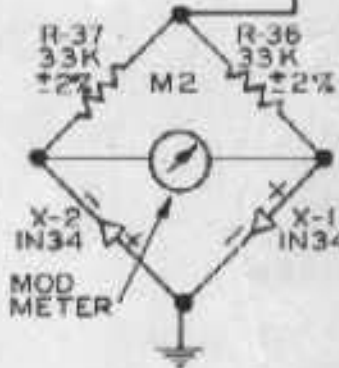

**Fig. 8. Schematic Wiring Diagram of 202-C FM Signal Generator**